

Standard Series BS12-18 12V18Ah

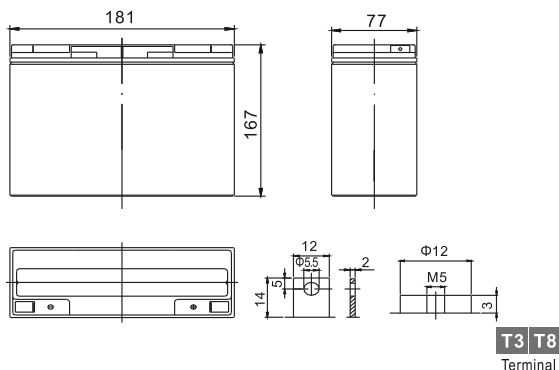

Dimension(mm)



Specification

Nominal Voltage		12 V
Capacity(20HR, 25°C)		18Ah
Dimension	Length	181mm (7.13inch)
	Width	77mm (3.03inch)
	Height	167mm (6.57inch)
	Total Height(T3/T8)	167mm(6.57inch)/167mm(6.57inch)
Approx. Weight		5.4kg (11.9lbs)

Characteristics

Capacity 20°C (68°F) To 1.70V/Cell	20 hour rate	18Ah
	10 hour rate	16.3Ah
	5 hour rate	14.4Ah
	1 hour rate	10.4Ah
	15 min rate	7.55Ah
Internal resistance(Fully charged, 25°C)		Approx. 17mΩ
Capacity affected by temperature (20HR)	40°C	102%
	25°C	100%
	0°C	85%
	-15°C	65%
Self-discharge (25°C)	3 month	Remaining Capacity: 91%
	6 month	Remaining Capacity: 82%
	12 month	Remaining Capacity: 65%
Nominal operating temperature		25°C ±3°C(77°F ±5°F)
Operating temperature range		-15°C~50°C(5°F~122°F)
Float charging voltage(25°C)		13.60 to 13.80V
Cyclic charging voltage(25°C)		14.50 to 14.90V
Maximum charging current		5.4A
Terminal material		Copper
Maximum discharge current		270A(5 Sec.)

The Relationship for Open Circuit Voltage and Residual Capacity (25°C)

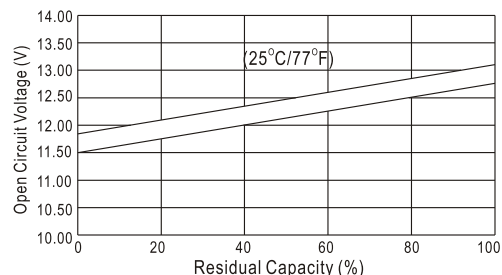

Charging Characteristics(25°C)

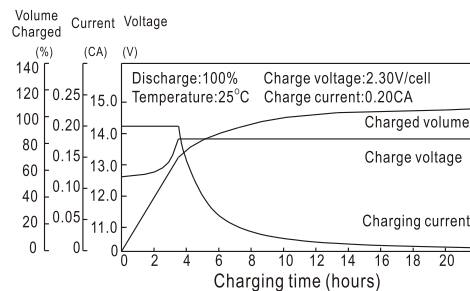

Cycle Life(25°C)

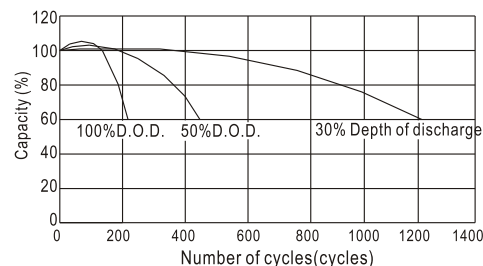

Constant Current Discharge Characteristics (A, 25°C)

F.V/TIME	5min	10min	15min	30min	60min	3h	5h	10h	20h
9.60V	63.0	39.6	31.5	18.9	10.8	4.38	2.92	1.64	0.91
10.2V	59.9	37.6	30.2	18.1	10.4	4.32	2.88	1.63	0.91
10.8V	56.3	35.4	28.7	17.2	9.85	4.23	2.82	1.62	0.90

Constant Power Discharge Characteristics (Watt, 25°C)

	5min	10min	15min	30min	60min	3h	5h	10h	20h
703	447	359	217	125	52.1	34.9	19.7	11.0	
668	424	345	208	120	51.3	34.4	19.6	10.9	
628	399	327	198	114	50.3	33.7	19.6	10.8	