

SAE16SF

Solar Wireless Siren and Strobe

General information

The SAE16SF package comprises a Solar Wireless Siren and Strobe and an associated siren transmitter unit which are compatible with any standard wireless or hard wired alarm system.

Housing

The Siren, Strobe Light and Solar Panel are all encapsulated within a tough polycarbonate housing. This housing provides full protection against adverse weather conditions. All electronic components are specially treated to ensure long, reliable, trouble free operation and an integral tamper switch gives maximum protection to the unit.

Solar Panel

The Solar Panel mounted on the housing will maintain a charge to the rechargeable battery during daylight hours. During darkness, a negligible amount of energy is released by the rechargeable battery to operate the Siren.

Rechargeable Battery

A high capacity 6V 1.2Ah sealed lead acid rechargeable battery ensures that the Siren is self maintainable during darkness and long winter periods.

Initial Power-up Battery

An alkaline 9V PP3 battery is supplied in the SAE16SF to provide the initial power to the system.

Siren Code

An encrypted code is set using a combination of miniature switches. This enables you to select a unique security code for your installation.

Siren TX Module

A small Transmitter Module is supplied for connection to any standard alarm panel. The module can be installed within any non-metallic panel, either complete, or if space is at a premium, as a PCB only using the special PCB mounting. Alternatively, where the Control Panel is of metal construction the TX module MUST be installed outside the panel.

Solar Wireless Siren

Location

The Solar Siren SAE16SF unit should be fitted to the outside of the building in a position that is clearly visible and at a height which is relatively inaccessible to an intruder.

To provide the optimum amount of sunlight to the Solar Panel, you should ideally mount the Solar Siren on a south facing wall. However, an easterly or westerly position will suffice.

Although the Solar Siren is designed to work on any aspect wall, you should refrain from siting the unit on a north facing wall where possible.

Shadows cast by neighbouring walls, trees and roof overhangs should also be avoided. In practice, the Solar Siren should be positioned a minimum of twice the width of the eaves overhang, below the eaves.

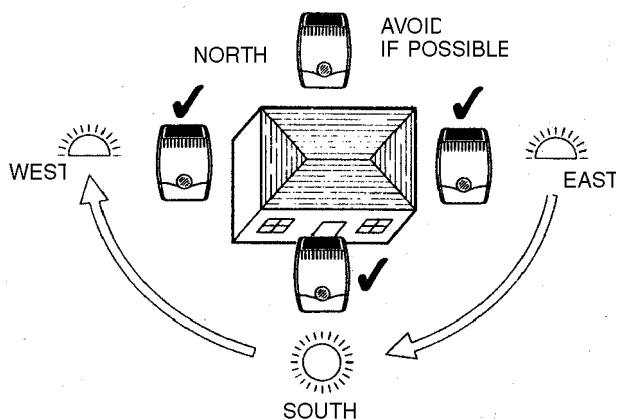

Remember that in winter the sun is lower in the sky and you should avoid winter shadows where possible. The Solar Siren contains a sophisticated radio receiver. However, reception of radio signals can be affected by the presence of metallic objects within the vicinity of the Solar Siren.

It is therefore important to mount the Solar Siren a minimum distance of 1 metre radius away from any external or internal metalwork, i.e. external drainpipes, gutters and internal radiators, mirrors, etc.

Installation

Remove the holding screw from the base of the housing and carefully hinge off the front cover. All electronic components are housed within the front cover. Use the rear black-plate as a template to mark the position of the four fixing holes on the external wall. Drill four holes and insert the plastic wall plugs. Mount the back-plate using the four screws provided.

Settings

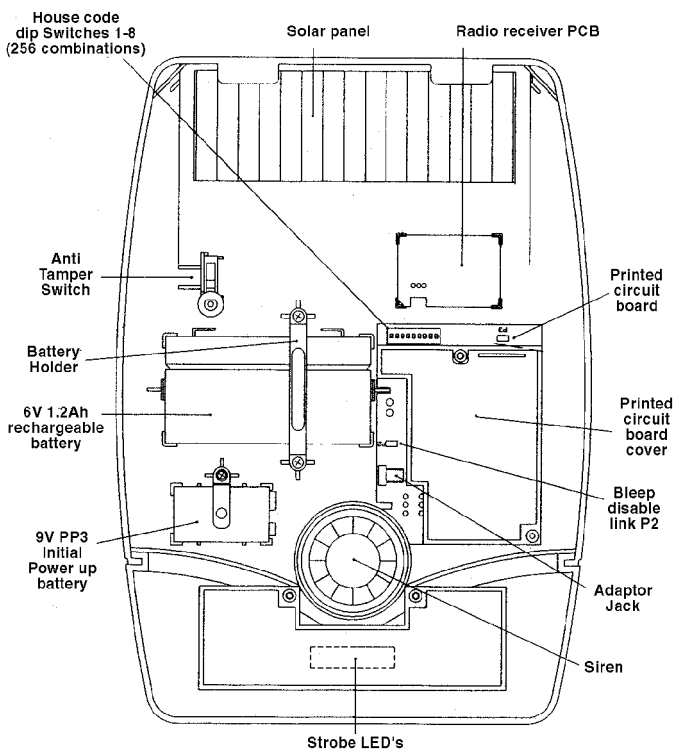

VIEW OF INSIDE SOLAR SIREN & STROBE

Siren Code

Within the SAE16SF Siren you will find a series of miniature dip switches.

NOTE: When the Siren is viewed as shown above (solar panel at top) the dip switches are "upside down".

Using a ball point pen set the miniature dip switches 1-8 to a random sequence of ON's and OFF's.

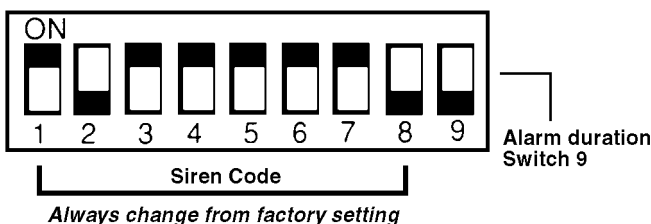

Make a note of the Siren Code dip switch settings as this will be needed when setting the Siren Transmitter Module.

IMPORTANT: When using the SAE16SF with a wireless alarm system do not set the "Siren Code" to the "House Code" used in the detector/remote controls.

Alarm Duration

This is maximum length of time that the Solar Siren and Strobe alarm will sound for, following an intrusion. Alarm duration can be set for either 3 or 15 minutes. Set dip switch 9 "OFF" for 3 minutes or "ON" for 15 minutes.

NOTE: Following activation into alarm condition the Solar Siren and Strobe will continue to sound until either the Control Panel is reset, or the Control Panel Cut Off time expires, or until the Siren and Strobe alarm duration time expires; whichever occurs first.

Initial Power-up

Once you have completed setting your Siren Code and Alarm Duration time, connect the 9V PP3 initial power-up battery to the clip-on connectors. Connect the rechargeable battery to the charging leads red to red(+) and black to black(-). Fit the siren and strobe cover to the black plate and secure using the holding screw. The strobe lamp will flash to confirm that the tamper switch has been closed. Remove the solar panel protection film. The installation of your Solar Siren and Strobe is now complete.

NOTE: Once the batteries have been connected, the unit will be operational and it is important that the solar panel receives sufficient light to maintain the battery charge. Also, the unit should not be repeatedly set into alarm as this could rapidly drain the battery.

Siren Transmitter Module

The SIREN Transmitter Module supplied is compatible with all standard control panels.

The SIREN Transmitter should be installed within or close to the alarm Control Panel. Alternatively, where space within the Control Panel is limited, the PCB can be carefully removed from its casing and mounted within the Control Panel using the PCB mounting bracket supplied.

Do not install the Siren Transmitter inside a metal cased enclosure, or within 1 meter of a metallic surface as this will impair the siren transmitter's radio range.

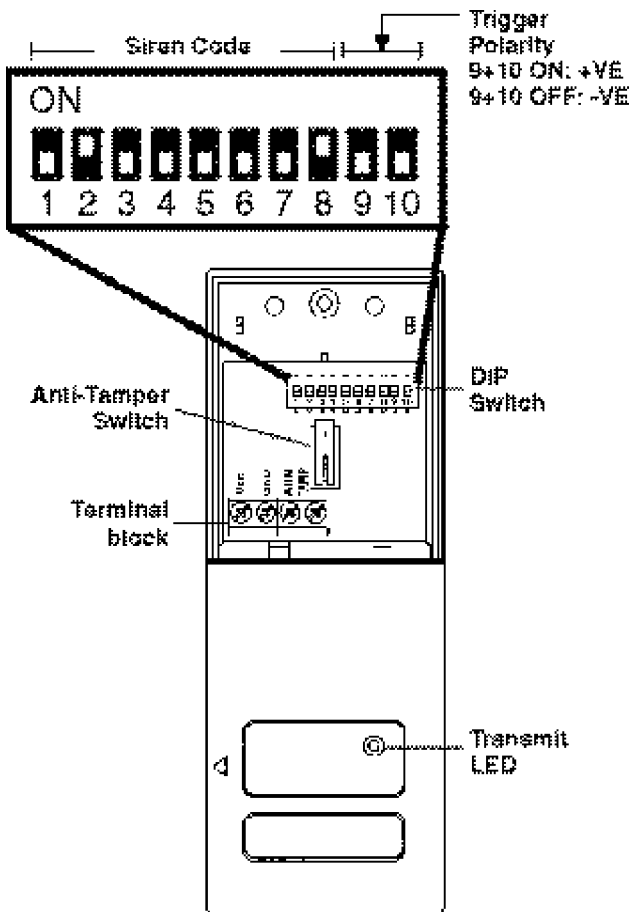

Settings

Set the miniature dip switches 1-8 to the same sequence of ON's and OFF's as set in the Solar Siren (the "Siren Code").

Do not set to the "House Code" used in wireless detectors remote controls, etc.

Set both dip switches 9 & 10 to suit the trigger polarity:

DIP SWITCHES 9&10 OFF: NEGATIVE TRIGGER

DIP SWITCHES 9&10 ON: POSITIVE TRIGGER

Refit the terminal cover and screw, and power-up the Control Panel.

Upon initial power-up the "Transmitter" LED should illuminate twice for approx. 4 seconds.

Operation

To test the operation of the Transmitter and Solar Siren and Strobe proceed as follows:

1. Set the Control Panel into alarm so that a full alarm condition occurs.
2. The "TRANSMIT" LED on the Transmitter Module should operate. Allow the alarm to sound for at least 5 seconds.
3. Cancel the alarm at the Control Panel. The "TRANSMIT" LED on the Transmitter Module should illuminate twice for approx. 4 seconds and the Solar siren and Strobe should cease to operate. If the Solar Siren and Strobe continues to operate, set the panel into an ALARM CONDITION, wait 5 seconds, and then cancel the alarm to make the Transmitter Module transmit the "Stop" signal again.

Maintenance

Your Solar Siren SAE16SF requires very little maintenance. However, a few simple tasks will ensure its continued reliability and operation.

1. At least once a year, preferably in the Autumn, the solar panel on the top of the siren housing should be cleaned using a soft, damp cloth. This operation will ensure that the solar panel receives all the available light. The cleaning operation can be combined with the general cleaning of the outside of the house, windows, etc. to reduce maintenance time.

2. The Solar Siren incorporates tamper protection for system security. Should you, for any reason, have to completely power down the Solar Siren (i.e. to move the system to a new premises), remove the holding screw at the base of the siren and hinge off the front cover. **WARNING-THE SIREN WILL SOUND.**

Disconnect the siren, the rechargeable battery and initial power-up battery and ensure that the solar panel is covered with a light proof material to prevent it being energised.

Undo the terminal cover screw and remove the terminal cover of the transmitter. REMOVE ALL POWER (230V~ MAINS AND BATTERY) FROM THE CONTROL PANEL. Lead the cable to the Control Panel terminals and connect as follows:

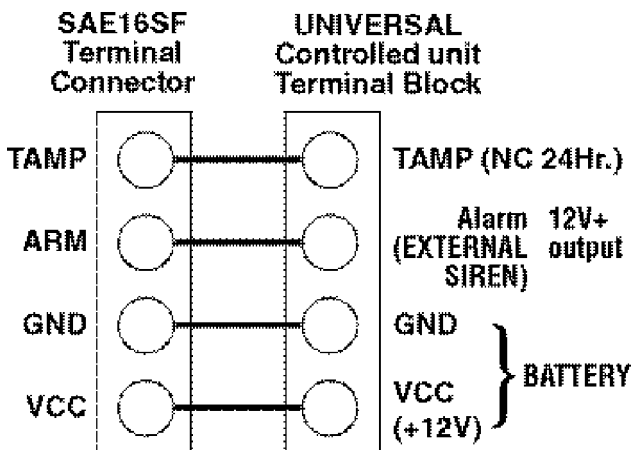

3. The Solar Siren should not be left for long periods with the batteries connected, unless the unit is able to receive sufficient light to maintain the battery charging circuit. Failure to maintain charge to the unit will result in the rechargeable battery running unacceptably low. Should this occur the unit must be recharged from a DC 7.5V— / 100mA mains adaptor.

When re-powering the Solar Siren SAE16SF, fit a new 9V PP3 leak proof alkaline Initial Power-up battery to ensure that the system receives sufficient power until the solar panel can recharge the main battery completely.

4. The main rechargeable battery has a typical life of 4 years and needs no maintenance during this period, providing the battery is kept charged. The battery will be damaged if it is stored in a discharged state.

Jamming Detect Function (Option)

In order to detect any attempts to jam the radio channel used, a special "Jamming Detect" feature is excluded. You can set the feature "ON" to cause the Solar Siren to sound for 4 seconds if the radio channel is jammed for more than 30 seconds.

Alternatively, where false alarms are being caused by unavoidable radio interference, it is better to leave the "Jamming Detect" feature. (Option).

Specification

- Casing material 3 mm Polycarbonate
- Dual front and rear anti-tamper
- Internal receiver and aerial 433MHz
- Solar panel 7.5V Charge Rate typically 60mA
- Time out switchable 3 minutes or 15 minutes
- Quiescent current 850µA (typical)
- Xenon Strobe current 125 mA (1 Watt)
- Piezo Sounder 110dB, current 150mA
- Operation time in complete darkness: 40 days
- Jamming Detection (optional)
- Anti Foam
- Range from TX Module up to 100 m in free air space
- Compatible with Repeater Unit
- Dimensions (mm): 300 x 260 x 85

Siren Transmitter

- Anti-tamper
- +VE or -VE trigger
- Pre wired for easy connection
- Fixing for external or internal use
- LED confirmation
- Attractive ABS moulding
- Power requirement DC 12V—

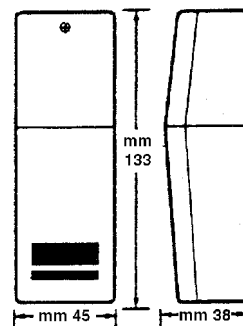

Accessories

Sometimes it is necessary to extend the range of wireless signals, so as to expand detection coverage of your wireless security system when the distance between the Control Panel and SAE16SF is too big. For this purpose is designed the:

HE16RIP SAE-RF Radio repeater for SAE16SF.
Power supply: DC 12V— provided with 230V~ adapter.
9V NiCd rechargeable battery optional.



HESA SpA

Via Triboniano, 25 - 20156 MILANO, Italy
Tel. ++39.02.38036.1 - Fax ++39.02.38036.701
Internet: www.hesa.com
e-mail: hesa@hesa.com

Filiale

Via Val Grana, 14 - 00141 ROMA, Italy
Tel. ++39.06.8861.415 - Fax ++39.06.8861.391
roma@hesa.com