



SecuriHeat d-LIST

Product Catalogue 2022

Introduction

Content

1.	Introduction.....	3
2.	System Overview.....	4
3.	Processor Units.....	5
4.	Overview scope of delivery	6
5.	Demo and Test Equipment	7
6.	Dongle license and d-List Config	8
7.	Cable d-List	9
8.	Single Sensor d-List.....	10
9.	Accessories d-List.....	11
10.	Spare Parts d-LIST	15
11.	Services.....	16
12.	Product Type Index	17

1. Introduction



SecuriHeat d-LIST heat detectors, where all other detectors reach their limits.

Dust, heat, smoke, exhaust fumes and other interference factors have a significant impact on detecting fires when using conventional fire detectors. However, it is exactly under such difficult conditions that the fire risk is so great and it is vital to ensure quick and reliable detection – such as in tunnels, industrial facilities, power plants and car parks.

With the SecuriHeat d-LIST line-type heat detectors, Securiton provides systems that can enable the rapid localisation of a fire – even when used in harsh, aggressive environments.

Safety in industrial facilities – the SecuriHeat d-LIST.

The SecuriHeat d-LIST line-type heat detector with SEC 15 sensor cable is ideally suited to applications with small monitoring areas. Two sensor cables with a maximum length of 350 metres each can be connected to the SCU 835 (sensor control unit) and put into operation at the touch of a button – and all without special aids or advance knowledge of the system. The monitoring system with a maximum of two sets of 100 sensors can be universally integrated in fire alarm systems. Several SCU 835 units can be networked easily for monitoring larger areas. The d-LIST system can also be expanded with individual temperature sensors in metal housings for monitoring critical areas such as drive units on belt conveyors and escalators, among others.

Outstanding flexibility – because every object needs individual protection.

The spacing between sensors can be freely selected, and it is even possible to combine different sensor spacing distances. You can see where the sensors are located according to the markings on the outer sheathing of the sensor cable. Another highlight (and one that is absolutely unique on the market) is the problem-free branching of the cable harnesses. External individual sensors in metal housings are available for special applications and can be easily connected to the SecuriHeat d-LIST system. Different sensor cable areas can be connected together with one signal cable.

Product

The descriptions and technical data included in this catalogue are up-to-date at the time of release. We reserve the right to make alterations to them, particularly where justified by technological advancements. The illustrated products may also differ visually from the products supplied as a result of continuous further development of products.

The layout of this catalogue is subject to copyright. The copying or reuse of text, illustrations and photos in any media contained within this catalogue - also in an abridged form - is only allowed with our explicit written permission. We assume no liability for typographic errors and obvious mistakes. Please quote the relevant item numbers when making enquiries or placing an order.

Delivery conditions are regulated in the “General Terms and Conditions of Securiton AG for Export Deliveries”

System Overview

2. System Overview

d-LIST system design

Typical installations of the SCU 835 d-List controller with the SEC15 sensor cable

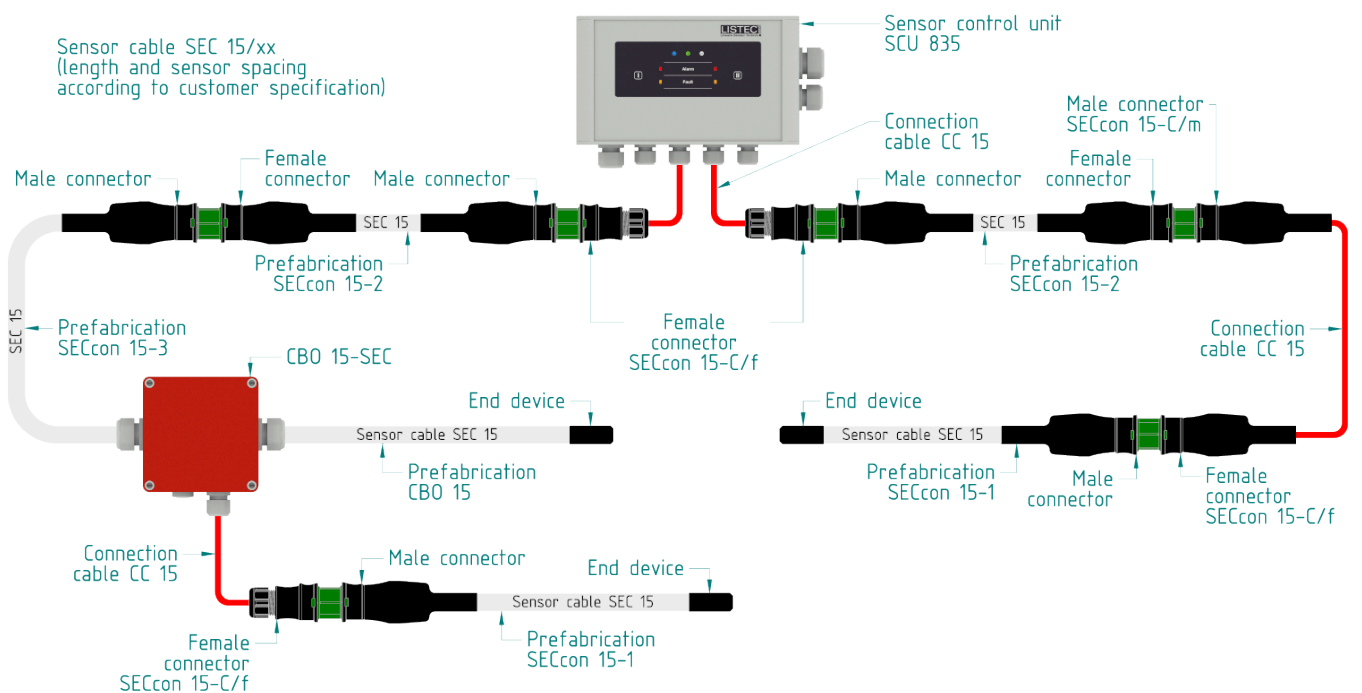
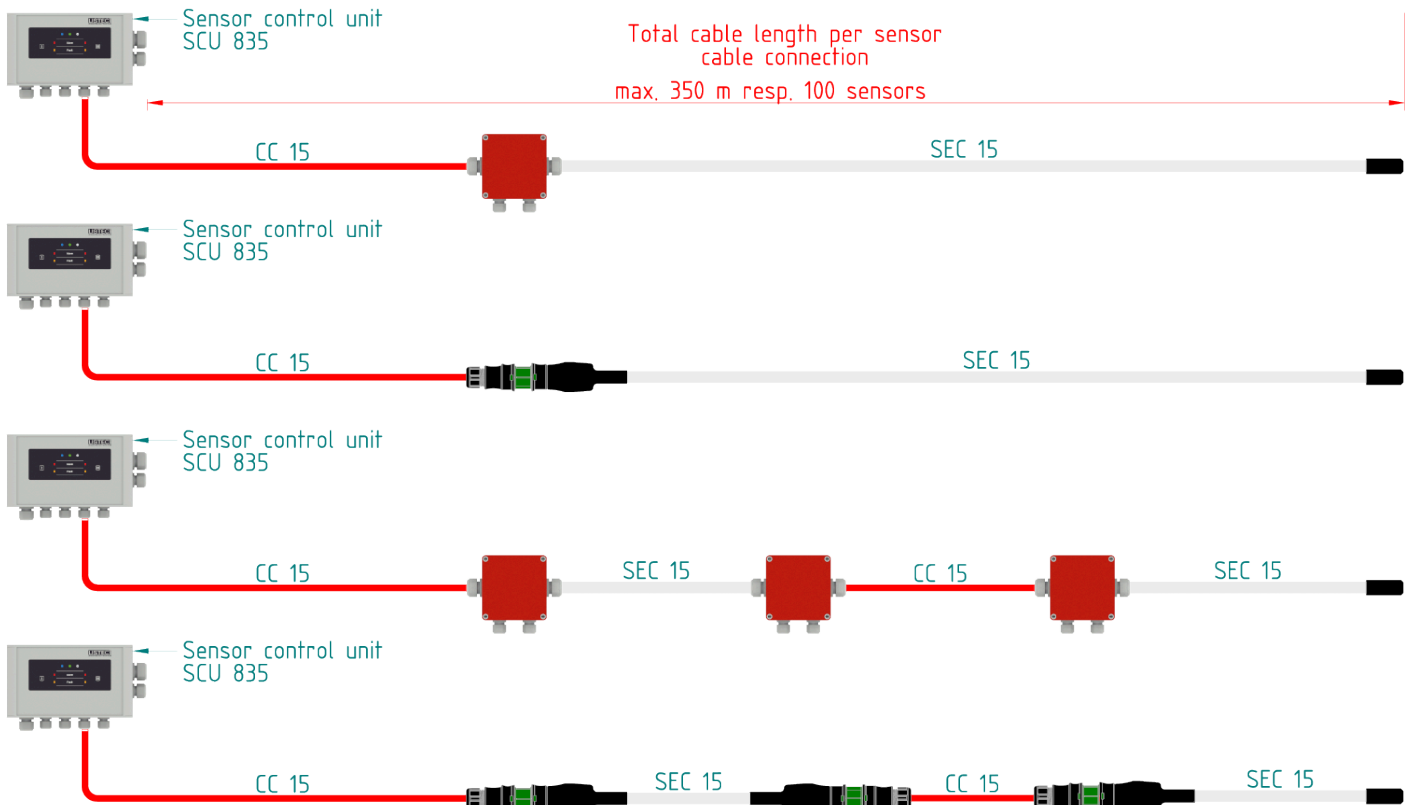

3. Processor Units

Sensor Control Unit



SCU 835

62-2001001-04-01

d-LIST is a temperature measuring system or a resettable linear heat detector according to EN 54-22, based on a sensor cable. Due to its closed cable construction and the high measuring resolution, the system can be used even under the harshest environmental conditions.

A fire alarm is generated if either a given maximum threshold is exceeded, or if an increase in temperature takes place within a certain time (differential evaluation). The two thresholds (set-points) can be set individually for each of the attached sensor cables.

The measurement resolution of 0,1° gives the system a high sensitivity. The tried and tested algorithms used in the evaluation eliminate false alarms due to natural temperature variations.

Operating voltage:	10.5 to 30 VDC
Power consumption:	150 mA
Operating temperature:	-25°C to +70°C
Weight:	SCU835: 1,95 Kg

Dimensions (HxWxD):	289.5 x 177.5 x 91 mm
Material:	aluminium

Approvals

VdS-Approval:	G 221004
---------------	----------

Accessories		
Relaisboard 16 contacts	REL 835	62-4001004-01-02
Connectors for communication ports	AP2 DLCON/SCU8 35	62-4001023-01-01
Mounting plate BX-OI3	AP BX-OI3	62-4001002-01-01
Mounting plate XLM 35	AP XLM 35	62-4001001-04-01

Overview scope of delivery

4. Overview scope of delivery

Ordering article	Included accessory	Description
SCU 835	AG1 DLCON/SCU835 AP1 DLCON/SCU835	Basic delivery
AP2 DLCON/SCU835	---	Optional: Special connector for: LAN, RS232/485 and I/O's
REL 535	---	Optional: Additional 16 relay contacts
ACCS-AP REL 835	---	Accessory bag for REL 535 board with connection cable, mounting material and screws
AP XLM 35	ACCS-AP XLM 35	Optional: Usage of XLM 35 loop module
CBO 15-SEC	UCM 15-SEC AG1 CBO 15-SEC	SEC-15 cable connections
CBO 15-ESD	UCM 15-ESD AG1 CBO 15-ESD	ESD single sensors connection

5. Demo and Test Equipment

d-LIST Demo Case SCU 835



DemoCase SCU 835

62-2001017-02-01

Demo case for the d-LIST system in a transport case with wheels and telescope handle.

Including sensor control unit SCU 835, sensor cable SEC 15 with two sensors, one external sensor ESD-A5-EL-01 and ESD-A5-RL-01 each with 10 built-in d-LIST sensors and Bluetooth adapter.

Optionally, the version DemoPlate SCU835 can be ordered as a prefabricated demo plate. This mounting plate can be installed in a predecessor d-List DCU demo case.

Mains voltage:	100-230VAC
Power consumption:	<500mA
Operating temperature:	0°C to +60°C
Weight of basic version:	8.6 kg
Dimensions (HxWxD):	550 x 400 x 230 mm

Accessories		
d-LIST Demo Plate SCU 835	DemoPlate SCU835	62-4001031-02-01

Dongle license and d-List Config

6. Dongle license and d-List Config

d-LISTconfig Operation **Limited access** for d-List Config software.
Only read functions and the following write functions are possible:

- Reset
- Set date & time
- View maximum and maximum difference temperatures
- LED Test
- Switching sensors off and on

d-LISTconfig Maintenance Additional to Operation level:

- Save configuration
- Clear lists (events & both max. temperatures)
- Relay test
- Adjust alarm thresholds
- Simulation (alarm and fault)

d-LISTconfig Commissioning Additional to Maintenance level (Full Access):

- Configure
- Save configuration, edit offline, load into SCU 835

Dongle order form available on the Securiton Homepage:

<http://www.securiton.com>

Software

d-List config Software	GUI d-LISTconfig	62-3201002-01-01
------------------------	------------------	------------------

d-List Dongle license

d-LISTconfig Operation	d-LISTconfig Opera	VE100430
d-LISTconfig Maintenance	d-LISTconfig Maint	VE100431
d-LISTconfig Commissioning	d-LISTconfig Commi	VE100432

Securiton Dongles

Dongle for Securiton Applications (without license)	ULM-DP	VE100450
Dongle for Securiton Applications (without license) Pack of 5 Dongles	ULM-DP 5	VE100451
Dongle for Securiton Applications (without license) Pack of 10 Dongles	ULM-DP 10	VE100452

7. Cable d-List

Remote Display Unit



SEC 15/01	sensor distance 1m	62-2000360-00-00
SEC 15/02	sensor distance 2m	62-2000367-00-00
SEC 15/03	sensor distance 3m	62-2000372-00-00
SEC 15/04	sensor distance 4m	62-2000374-00-00
SEC 15/05	sensor distance 5m	62-2000376-00-00
SEC 15/10	62-2001014-01-01 (ergänzen)	

The cable is able to measure temperatures from -40°C to +85°C (for short periods +120°C) with a resolution of 0,1° Celsius.

Cable structure:

- Hybrid circuits mounted on a 2 core flat flexible cable
- Filling material with strain relief, which secures the cable in case of fire
- Aluminium shield
- Halogenfree cable sheath; flame retardant and non-corrosive, with sensor marking

Operating temperature:	-40°C to +120°C
Weight:	0,35 kg / m
Sheath material:	HM4 mixture, halogen free, flame retardant
Color:	grey

Approvals

VdS-Approval:	G221004
---------------	---------

8. Single Sensor d-List

External Sensor rectangular



ESD-A5-EL-01	1m	62-2000343-00-00
ESD-A5-EL-05	5m	62-2000346-00-00
ESD-A5-EL-10	10m	62-2000499-00-00

Stainless steel sensor A5 for use with the d-LIST-System, whereby all sensors are connected in parallel via standard terminals. These sensors can be used together with SEC15 sensor cable and the control unit SCU835.

Design: rectangular 8 mm

Operating temperature:	-40°C to +150°C
Material:	Stainless steel

External Sensor round

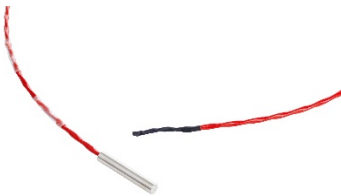

ESD-A5-RL-01	1m	62-2000347-00-00
ESD-A5-RL-05	5m	62-2000350-00-00
ESD-A5-RL-10	10m	62-2000498-00-00

Stainless steel sensor A5 for use with the d-LIST-System, whereby all sensors are connected in parallel via standard terminals. These sensors can be used together with SEC15 sensor cable and the control unit SCU835.

Design: round 8 mm

Operating temperature:	-40°C to +150°C
Material:	Stainless steel

9. Accessories d-List

Mounting Material d-List

Clamps



Cable clamp for SEC 15
delivery unit: 100 pcs

CLIC 15

62-8000304-00-00



Pipe clamp for SEC 15 with locking clip

MDC

62-8000344-00-00

Various mounting material



Stainless steel screw to mount CLIC 17 cable clamp
delivery unit: 100 pcs

Screw Torx

62-8000303-00-00



Nylon dowel screw to mount CLIC 17 cable clamp
delivery unit: 100 pcs

Dowel

62-8000301-00-00



Stainless steel cable clamp, grade 1.4571, stainless steel
dowel and cable fastener must be ordered separately

MDJ 1.4571

62-8000349-00-00



Stainless steel dowel grade 1.4571, to mount MDJ 1.4571

Dowel/Nut 1.4571

62-8000414-00-00



Stainless steel cable clamp, grade 1.4529, stainless steel
dowel and cable fastener must be ordered separately.

MDJ 1.4529

62-8000374-00-00



Stainless steel dowel grade 1.4529, to mount MDJ 1.4529

Dowel/Nut 1.4529

62-8000411-00-00



Cable fastener for line mounting

FEMC

62-8000384-00-00



Protection for MDJ clamp and line mounting fastener in the
event of a fire

FECT 201-A4

62-8000360-00-00

Accessories d-List

Connection Box CE



CBO 15-SEC

62-2001004-01-01

Connection unit for one or two temperature sensor cable SEC15 including an universal connection module UCM. If it is not possible to connect the sensor cable directly to the sensor control unit SCU835, the connection cable CC15 can connect sensor control unit and sensor cable via the connection box. In the box the connection cable and the sensor cable are linked together via the connection module UCM. If short transmission lines are linked the universal connection module has the possibility to activate adaptation resistors.

Protection class:	IP66
Operating temperature:	-35°C to +60°C (short period +80°C)
Dimensions (HxWxD):	130 x 130 x 75 mm
Material:	glass-fibre reinforced, polycarbonat

Connection Box CE



CBO 15-ESD

62-2001004-02-01

Connection unit for up to eight external sensors ESD or four single sensors and one LIST-cable SEC15. The external sensors can be connected to the SEC15 sensor cable bus via the connection box. It is possible to connect up to eight single sensors to the bus or four sensors and a sensor cable. Every connection has an adaption resistance. This can be activated, if needed, for example for short adaptation resistors.

Protection class:	IP66
Operating temperature:	-35°C to +60°C (short period +80°C)
Dimensions (HxWxD):	130 x 130 x 75 mm
Material:	glass-fibre reinforced, polycarbonat

Connection Cable

CC 15

62-8000345-00-00







LISTEC supply cable 1x2x0.8, shielded, JE-H(ST)H E30, for an SEC 15 sensor cable.

If it is not possible to connect the sensor cable directly to the sensor control unit SCU835, the connection cable CC15 can connect sensor control unit and sensor cable via the connection box.



Operating temperature:	-30°C to +70°C
Sheath material:	HM2 compound, flame retardant
Color:	red

d-List Accessories

Cables

	Sensor cable with termination cap, CLB2 and shield connector.	SEC 15 fit box	62-3000354-00-00
	Sensor cable pre-fabrication with plug, 3-pin and termination cap.	SECcon 15-1	62-3000351-00-00
	Sensor cable pre-fabricated with plug and socket, 3 pin	SECcon 15-2	62-3000352-00-00
	Coupling with socket, 3-pin	SECcon 15-Cf	62-8000403-00-00
	Coupling with plug, 3 pin	SECcon 15-Cm	62-8000404-00-00

Tools

	LIST crimping tool for 2-and 4-core flat cable connectors	CLCT	62-8000347-00-00
	Cable scissors for SEC sensor cable	Cutter SEC	62-0000427-00-00

Accessories d-List

Service case



SC 15/20

62-2000432-00-00

Service case with tool for repair and connection of sensor cable.

Content:

Article	Quantity
Tool case	1
Manual SCU835/SEC 15	1
LIST-Crimping tool, adjusted	1
Cable cutter	1
Cable knife	1
Cable-stripping tool	1
Selection of 6 screwdrivers	1
Size 3 electronic screwdriver	1
Electronic side cutter	1
Side cutter	1
Multigrippliers	1
Combination pliers	1
Clincher male CLS2	15
Clincher female CLB2	15
Clincher strain relief CLVS	15
Shield connector SEC 15	10
End cap END 15	2
Clamp Clic 15	10
CCM modul SEC 150-A	1
UCM-SEC	1
Sleeve SEC 15	2
Isolating tape	1
Tape to vulcanize	1

10. Spare Parts d-LIST

Accessories and Spare Parts

Repair spare parts



Main board for SCU SCU 835
For repair only

MB SCU 835

62-4001003-02-03

Universal connection module



Connection module for up to eighth singel sensors ESD

UCM 15-ESD

62-4001005-02-01



Connection module for up to two sensor cabses SEC 15

UCM 15-SEC

62-4001005-01-01

Various spare parts



Shield connectors for connecting sensor cables.
with ring connector

SCON 15/0

62-4000315-00-00



Shield connectors for connecting sensor cables.
with Pin

SCON 15/1

62-4000316-00-00



Ribbon cable crimping connector, 2-core, socket
delivery unit: 100

CLB 2

62-8000315-00-00



For locking a CLB clincher with pin plug
delivery unit: 100

CLVP

62-8000320-00-00



End cap for sensor cable SEC 15

END

62-8000503-00-00



Shrink sleeve with ribbon cable connection, shield connector,
plug and socket, and sealing material.
For connecting two SEC 15 cables

N15 Repair

62-2000396-00-00

11. Services

SecuriHeat LIST Commissioning

Support Fee



Commissioning support fee for projects within Europe.

Commission EU

11-5000001-01-01



Commissioning support fee for projects at Overseas.

Commission OvS

11-5000002-01-01

12. Product Type Index

C		
CBO 5-ESD-T	12	
CBO 5-SEC	12	
CC 15	13	
CLB 2	15	
CLCT	13	
CLIC 15	11	
CLVP	15	
Commission EU	16	
Commission OvS	16	
Cutter SEC	13	
D		
DemoCase SCU 835	7	
d-LISTconfig Commi	8	
d-LISTconfig Maint	8	
d-LISTconfig Opera	8	
Dowel	11	
Dowel/Nut 1.4529	11	
Dowel/Nut 1.4571	11	
E		
END	15	
ESD-A5-EL-01	10	
ESD-A5-EL-05	10	
ESD-A5-EL-10	10	
ESD-A5-RL-01	10	
ESD-A5-RL-05	10	
ESD-A5-RL-10	10	
F		
FECT 201-A4	11	
FEMC 270	11	
G		
GUI d-LISTconfig	8	
M		
MDC	11	
MDJ 1.4529	11	
MDJ 1.4571	11	
N		
N15 Repair	15	
S		
SC 15	14	
SCI 800 LP	15	
SCON 15/0	15	
SCON 15/1	15	
Screw Torx	11	
SCU 800-03	5	
SEC 15 fit box	13	
SEC 15/01	9	
SEC 15/02	9	
SEC 15/03	9	
SEC 15/04	9	
SEC 15/05	9	
SECcon 15-1	13	
SECcon 15-2	13	
SECcon 15-Cf	13	
SECcon 15-Cm	13	
U		
UCM-ESD	15	
UCM-SEC	15	
ULM-DP	8	
ULM-DP 10	8	
ULM-DP 5	8	

Product Type Index